

## **Comparison of mechanical properties of peripheral self-expanding Nitinol and balloon-expandable stainless-steel stents**

W. SCHMIDT<sup>1</sup>, R. ANDRESEN<sup>2</sup>, P. BEHRENS<sup>1</sup>, K.-P. SCHMITZ<sup>1</sup>

<sup>1</sup>Institute for Biomedical Engineering, University of Rostock

<sup>2</sup>Department of Radiology, Hospital Guestrow, Academic Teaching Hospital, University of Rostock

**Purpose:** Balloon-expandable and self-expanding peripheral stents were investigated mechanically in order to compare their suitability for the use in specific vascular regions. The mechanical parameters were selected with special concern to their clinical relevance, which is given by the ability of stents to support narrowed vascular regions, to be placed accurately at the implantation site, and to follow vessel curvatures or bending deformations of vessels without mechanical irritations.

**Materials and Methods:** In-vitro tests included: Guidant Acculink, Cordis Precise and Bard Luminexx for self-expanding Nitinol stents and Boston Scientific Express Vascular, Medtronic Bridge and Biotronik Peiron as balloon-expandable stainless-steel stents. All stents were 8 mm in diameter and 36-40mm long (figure 1 – 6).

The flexural stiffness, change in length upon expansion, and radial strength were measured. The following test arrangements and test methods, developed and standardized at the Institute for Biomedical Engineering, University of Rostock, and the Institute for ImplantTechnology and Biomaterials, Rostock-Warnemuende, were used for the individual measurements.

### **Flexural stiffness:**

To measure the flexural (bending) stiffness the test object is fixed by a grip in a special sample holder (Figure 7). In case of the expanded stents an additional cylindrical rod is inserted into the stent to avoid stent damage in the grip region. The flexibility is not affected by this rod. The free bending length  $l$  is 12 mm. The bending deformation  $f$  is applied automatically using the linear actuator. The resulting force  $F$  is measured by the load cell which is contacted by a special device (see Figure 7). The load cell (Q11/10g) has a range of  $\pm 100$  mN at an accuracy of  $\pm 0.5\%$  FS.

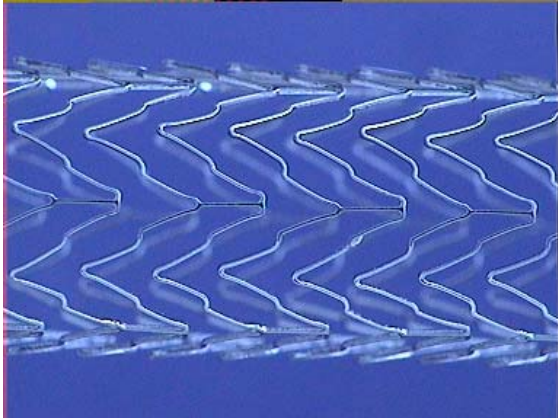

**Figure 1: Guidant Acculink**

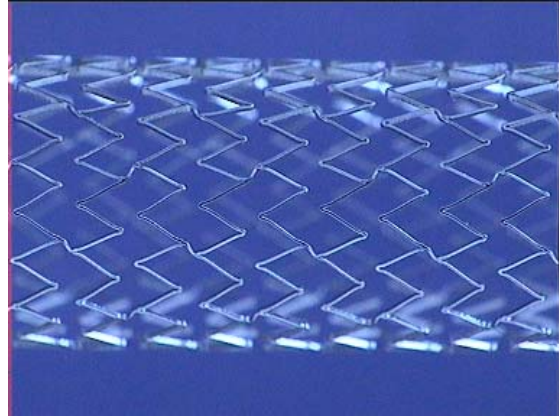

**Figure 2: Cordis Precise**

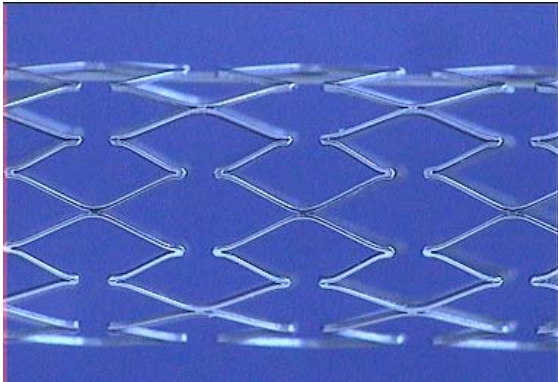

**Figure 3: Bard Luminexx**

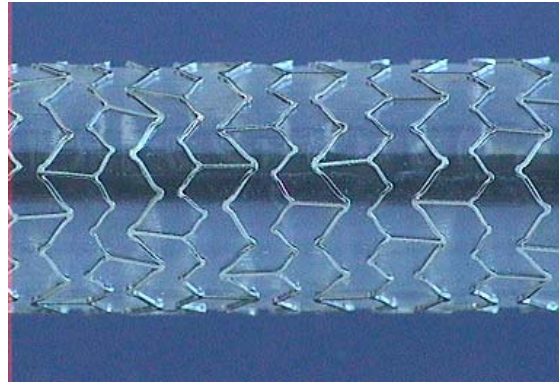

**Figure 4: Boston Scientific Express**

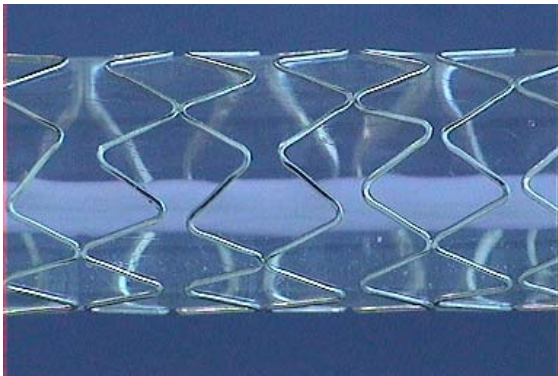

**Figure 5: Medtronic Bridge**

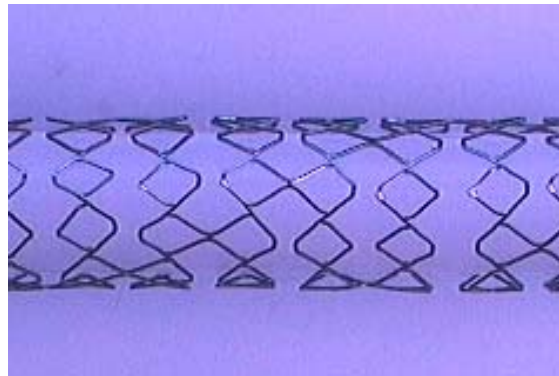

**Figure 6: Biotronik Peiron**

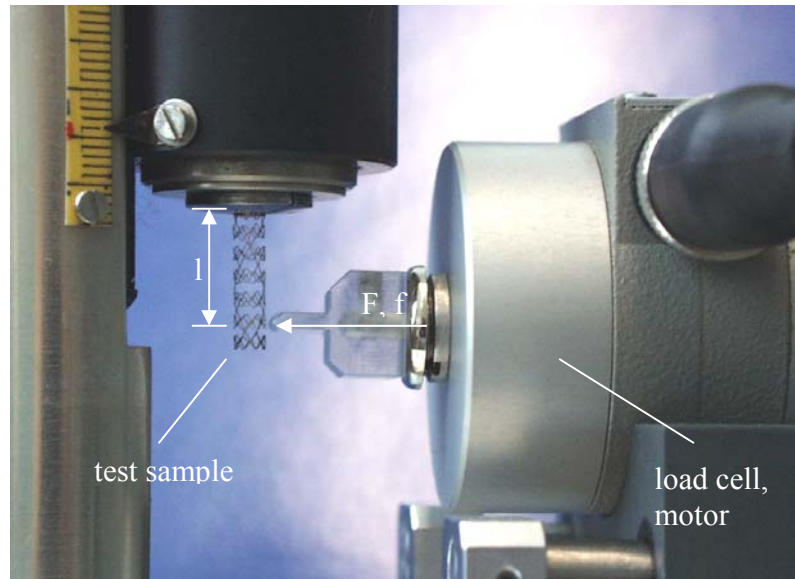

**Figure 7: Test setup for the measurement of the flexural stiffness**

The displacement and force information is recorded using a computer connected by a serial interface. The force distance curve describes the spring modulus of the test object for bending. The bending stiffness is calculated taking the mean value of  $F/f$  calculated by linear regression from the whole force-distance curve using the equation

$$EI = \frac{F \cdot l^3}{3f}$$

which is based on beam theory.

Taking into account possible asymmetric structures of the test samples the bending stiffness is measured in 5 directions around the circumference and averaged subsequently.

**Length change due to expansion:**

This parameter is measured by a scaled incident light microscope before and after stent expansion. Self-expanded stents may be non-visible on the stent delivery system (SDS) due to the surrounding tube of the SDS. In this case the stent length was measured using fluoroscopic images of the complete SDS together with a length standard as a reference in the same image.

**Radial strength:**

The measurement of radial strength is performed with an apparatus which is also used to determine outer diameters. For this test purpose however, the test chamber is sealed with a cover plate and connected to an electronic pressure controller by means of a tubing system. The stent to be measured is encased in a tube which simulates the vasculature and at the same time separates the stent from the temperature controlled (37°C) water bath. The tube is fabricated from polyurethane using a dip process. It has the same internal diameter as the stents nominal diameter and a wall thickness of 0.075mm. The connection of the stent to atmospheric pressure is accomplished with a pipe and a gland joint.

The diameter of the test sample in the chamber is precisely measured by a 2-axis laser scanning device in the center of the sample.

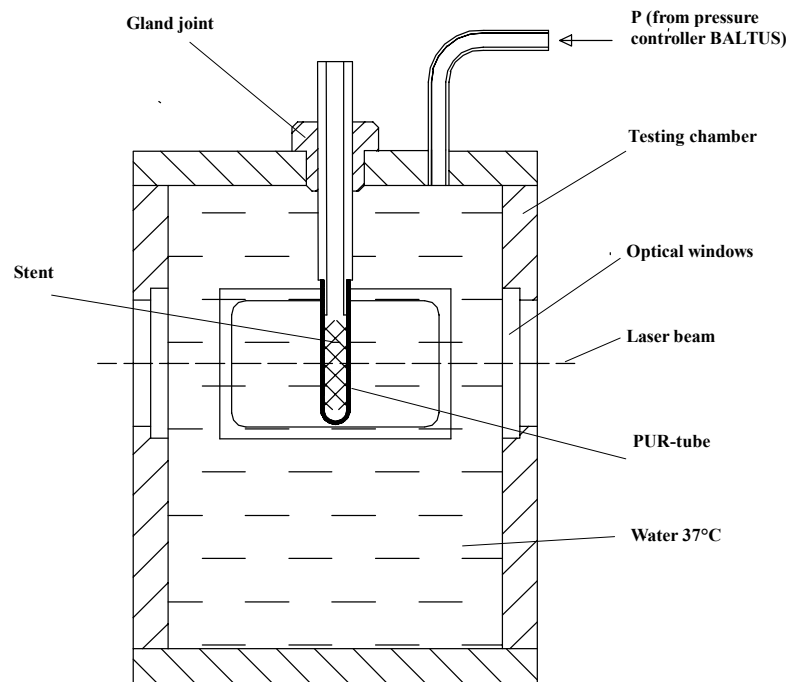

**Figure 8: Test chamber for the measurement of the radial strength of vascular stents**

The pressure in the test chamber is incrementally increased to 1.5 bar and applies a radial force on the PUR-tube covering the stent. From the data obtained, a pressure - diameter characteristic curve is generated until the collapse pressure is reached.

**Results:**

For self-expanding stents the stent flexural stiffness reached from 11.7 up to 88.1 Nmm<sup>2</sup> compared to 109.9 up to 522.0 Nmm<sup>2</sup> for the balloon-expandable stents.

**Flexural stiffness of self-expanding and balloon-expandable stents**  
expanded stents

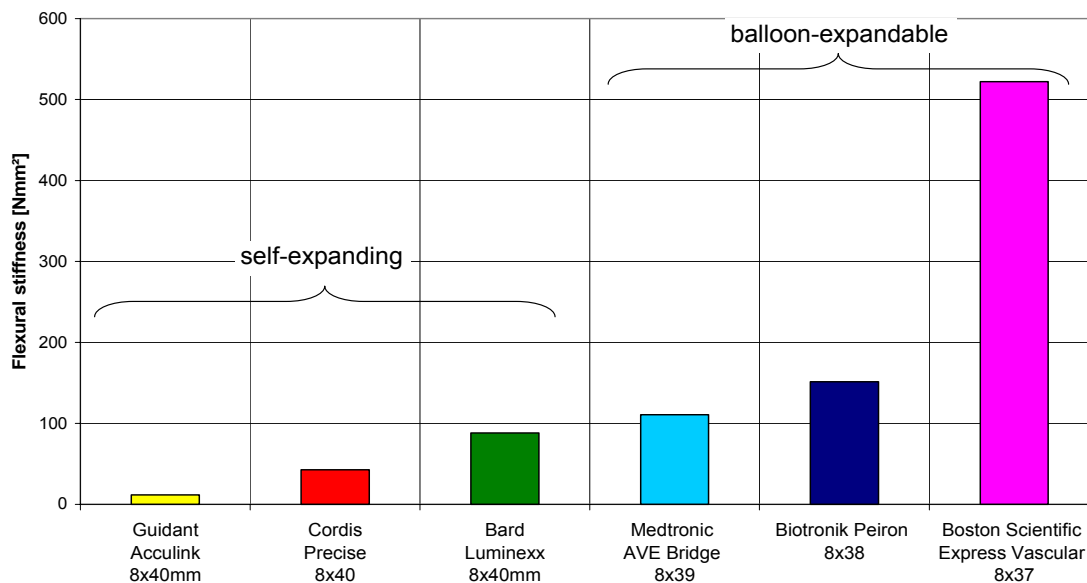

**figure 9: Flexural (bending) stiffness of expanded stents**

The length change was -7.25% up to +11.75% (self-expanding stents) and -6.57% to -0.50% (balloon-expandable stents). Self-expanding stents showed increasing as well as decreasing length depending on the individual stent design, while all balloon-expandable stents shortened during expansion process (denoted by a negative sign).

**Length change due to stent expansion**

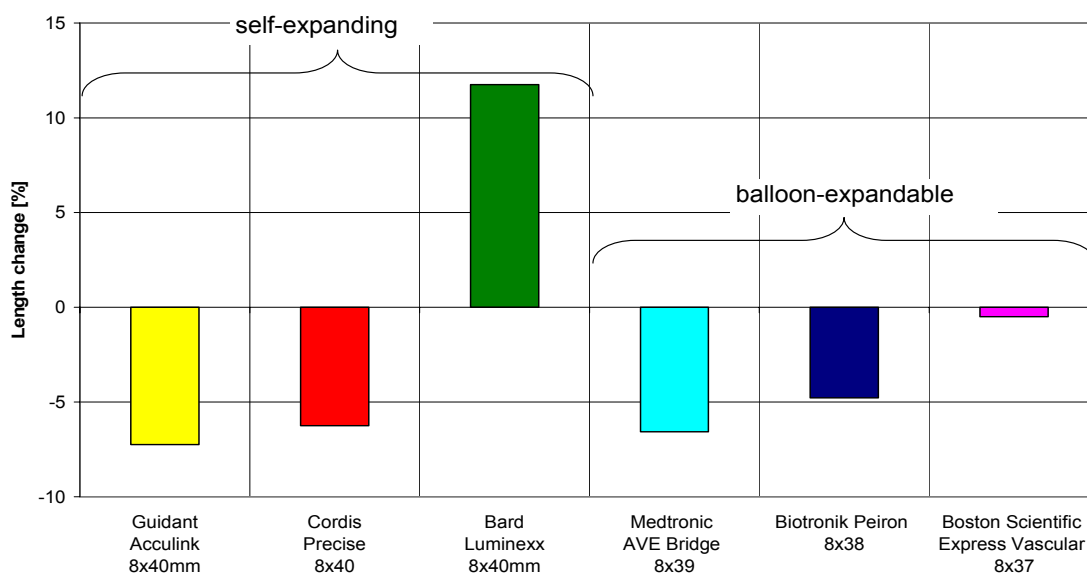

**figure 10: Length change due to stent expansion to nominal diameter**

The radial strength expressed as the collapse pressure was 0.18 – 0.25 bar (self-expanding stents) and 0.85 – 1.40 for the balloon-expandable stents of this study.

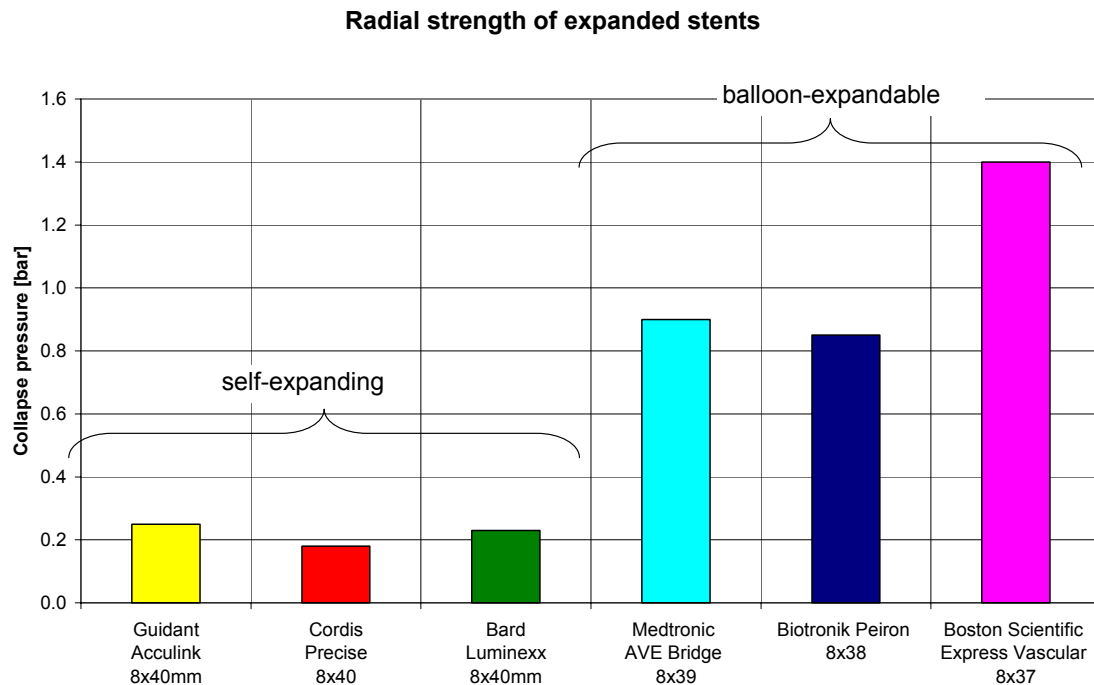

**figure 11: Collapse pressure of the expanded stents as a measure of their radial strength**

**Conclusion:**

The comparison of the selected stent parameters showed typical differences between the self-expanding and balloon-expandable stents. The bending stiffness of self-expanding stents was lower as compared to the balloon-expandable stents. That means they are more flexible which may be an advantage for application in tortuous vessels and vessels which could be loaded with bending moments.

The low flexural stiffness corresponds with the low collapse pressure of self-expanding stents compared to the balloon-expandable stent group of this study. This is caused by the different stent material and design principles of either Nitinol or stainless steel stents. Little is known about actual radial loading in pathologically altered vessels. So the assessment of critical values must be performed mostly on clinical experience. It can be assumed that balloon-expandable stents cover a large safety margin in radial strength while self-expanding stents are more adapted to the radial flexibility of normal arterial vessels and recover well due to their high elasticity after single over-loading.

The differences in length change depend on the stent design more than on the principle of stent expansion. For a precise placement stents should preferably have a small change in length due to expansion. This can be alleviated by exact knowledge of the stent behavior during deployment.

Currently there exist a lot of indications for stent application of both self-expanding and balloon-expandable stents. So the mechanical specifications for special indications may vary. The differences noted support the clinician in stent selection for a particular vascular lesion.

## References

1. Duda SH, Wiskirchen J, Tepe G, Bitzer M, Kaulich TW, Stoeckel D, Claussen CD: Physical properties of endovascular stents: an experimental comparison, *J Vasc Interv Radiol* 2000; 11(5): 645-54
2. Dyet JF, Watts WG, Ettles DF, Nicholson AA. Mechanical properties of metallic stents: How do these properties influence the choice of stent for specific lesions?, *Cardiovasc. Intervent. Radiol.* 2000; 23: 47-54.
3. Ormiston JA, Dixon SR, Webster MWI, Ruygrok PN, Stewart JT, Minchington I, West T. Stent longitudinal flexibility: A comparison of 13 stent designs before and after balloon expansion, *Catheteriz. and Cardiovasc. Interventions* 2000; 50: 120-124
4. Schmidt W, Andresen R, Behrens P, Schmitz KP.: Intrinsic properties of peripheral balloon-expandable stent systems. *Cardio Vascular and Interventional Radiology* 2002; 25 Suppl 2: 239.
5. Schmidt W, Behrens P, Behrend D, Schmitz K-P, Andresen R: Experimental study of peripheral balloonexpandable stents, *Progress in Biomedical Res.* 6 (2001) 5, 246-255
6. Schmidt W, Andresen R, Behrens P, Schmitz K-P: Mechanische Eigenschaften peripherer ballonexpandierbarer Stentsysteme, *Fortschr. Röntgenstr.* 174 (2002), S. 1430-1437